

1200 Series / 1600 Series - OEM Transducers Featuring Exceptional Proof Pressure and Stability Specifications

- ▶ Gauge, Vacuum, and Compound Pressure Models
- ▶ General Purpose and Wash down Enclosures
- ▶ High Proof Pressure Achieved by Thicker Diaphragm Construction
- ▶ Voltage and Current Output Models

The 1200 Series features stability and toughness via its CVD and ASIC design coupled with a thicker diaphragm. The thicker diaphragm enables these sensors to survive most pressure spikes caused by pump ripple, solenoid valves, etc. The 1600 Series extends the packaging options by providing an all welded stainless steel back end for demanding industrial applications. A modular design allows special ordering of fittings, electrical cables, etc. for OEM applications. The ASIC and CVD technology enables Gems to offer almost any output over any pressure range.

Specifications

Input	
Pressure Range	Vacuum to 400 bar (6000 psi)
Proof Pressure	4 x Full Scale (FS) (<1% FS Zero Shift)
Burst Pressure	>35 x FS <= 4 bar (60 psi); >20 x FS <=40 bar (600 psi); >5 x FS <= 400 bar (6000 psi)
Fatigue Life	Designed for more than 100 million FS cycles
Performance	
Supply Voltage Sensitivity	0.01% FS/Volt
Long Term Drift	0.2% FS/year (non-cumulative)
Accuracy	0.5% FS typical
Thermal Error	2.0% FS typical
Compensated Temperatures	-20°C to 80°C (-5°F to 180°F)
Operating Temperatures	-40°C to 125°C (-40°F to 260°F) for elec. codes A, B, C, 1 -20°C to 80°C (-5°F to 180°F) for elec. codes 2, D, G, 3 -20°C to 50°C (-5°F to 125°F) for elec. code F temperatures >100°C supply is limited to 24 VDC
Zero Tolerance	1% of span
Span Tolerance	1% of span
Response Time	0.5 ms
Mechanical Configuration	
Pressure Port	see ordering chart
Wetted Parts	17-4 PH Stainless Steel
Electrical Connection	see ordering chart
Enclosure	316 SS, 17-4 PH ss IP65 NEMA 4 for elec. codes A,B,C,D,G,1,2,3 IP67 for elec. codes F IP30 for elec. code "3" with flying leads
Vibration	70g, peak to peak sinusoidal, 5 to 2000 Hz (Random Vibration: 20 to 200 Hz @ ≈20g Peak per MIL-STD.-810E Method 514.4)
Acceleration	100g steady acceleration in any direction 0.032% FS/g for 1 bar (15 psi) range decreasing logarithmically to 0.0007% FS/g for 400 bar (6000 psi) range.
Shock	20g, 11 ms. per MIL-STD.-810E Method 516.4 Procedure I
Approvals	CE, UR (12 ET, 16 ET Intrinsically safe)
Weight	approx. 100 grams (additional; cable 75 g/m)



PRESSURE TRANSDUCERS

Along with the superiority of the CVD strain gauge, Psibar® transducers incorporate components to leverage the sensing element's strength. The output is a product with a unique balance of performance and value unmatched in today's pressure sensing market.

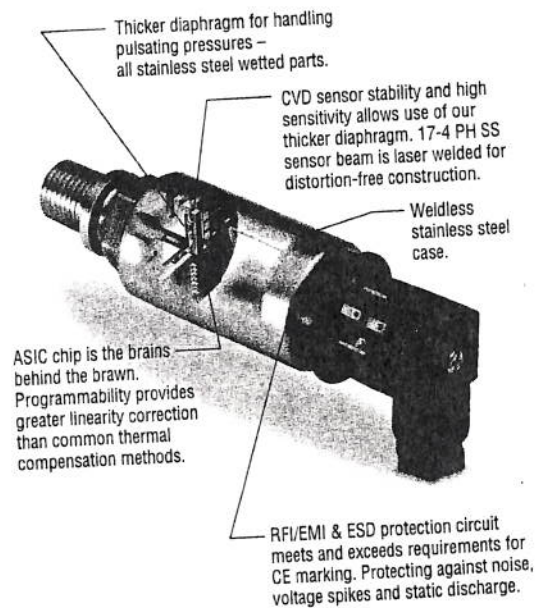

1200 Series / 1600 Series - OEM Transducers Featuring Exceptional Proof Pressure and Stability Specifications

- ▶ Gauge, Vacuum, and Compound Pressure Models
- ▶ General Purpose and Wash down Enclosures
- ▶ High Proof Pressure Achieved by Thicker Diaphragm Construction
- ▶ Voltage and Current Output Models

The 1200 Series features stability and toughness via its CVD and ASIC design coupled with a thicker diaphragm. The thicker diaphragm enables these sensors to survive most pressure spikes caused by pump ripple, solenoid valves, etc. The 1600 Series extends the packaging options by providing an all welded stainless steel back end for demanding industrial applications. A modular design allows special ordering of fittings, electrical cables, etc. for OEM applications. The ASIC and CVD technology enables Gems to offer almost any output over any pressure range.

Specifications

Input	
Pressure Range	Vacuum to 400 bar (6000 psi)
Proof Pressure	4 x Full Scale (FS) (<1% FS Zero Shift)
Burst Pressure	>35 x FS <= 4 bar (60 psi); >20 x FS <=40 bar (600 psi); >5 x FS <= 400 bar (6000 psi)
Fatigue Life	Designed for more than 100 million FS cycles
Performance	
Supply Voltage Sensitivity	0.01% FS/Volt
Long Term Drift	0.2% FS/year (non-cumulative)
Accuracy	0.5% FS typical
Thermal Error	2.0% FS typical
Compensated Temperatures	-20°C to 80°C (-5°F to 180°F)
Operating Temperatures	-40°C to 125°C (-40°F to 260°F) for elec. codes A, B, C, 1 -20°C to 80°C (-5°F to 180°F) for elec. codes 2, D, G, 3 -20°C to 50°C (-5°F to 125°F) for elec. code F temperatures >100°C supply is limited to 24 VDC
Zero Tolerance	1% of span
Span Tolerance	1% of span
Response Time	0.5 ms
Mechanical Configuration	
Pressure Port	see ordering chart
Wetted Parts	17-4 PH Stainless Steel
Electrical Connection	see ordering chart
Enclosure	316 SS, 17-4 PH ss IP65 NEMA 4 for elec. codes A,B,C,D,G,1,2,3 IP67 for elec. codes F IP30 for elec. code "3" with flying leads
Vibration	70g, peak to peak sinusoidal, 5 to 2000 Hz (Random Vibration: 20 to 200 Hz @ ≈20g Peak per MIL-STD.-810E Method 514.4)
Acceleration	100g steady acceleration in any direction 0.032% FS/g for 1 bar (15 psi) range decreasing logarithmically to 0.0007% FS/g for 400 bar (6000 psi) range.
Shock	20g, 11 ms, per MIL-STD.-810E Method 516.4 Procedure I
Approvals	CE, UR (12 ET, 16 ET Intrinsically safe)
Weight	approx. 100 grams (additional; cable 75 g/m)



PRESSURE TRANSDUCERS

Along with the superiority of the CVD strain gauge, Psibar® transducers incorporate components to leverage the sensing element's strength. The output is a product with a unique balance of performance and value unmatched in today's pressure sensing market.

