

#14075

Topling Farms

4RSP H W/65" AH

A. H. Fan



FILTER WARN



LOW

HYDRAULIC

GROUND DRIVE



OIL

Lo RANGE



Lo RANGE

GROUND

DRIVE

4X4



4X2



FUEL PUMP

BACK UP



LIGHTS



FLASHERS

PARKING BRAKE



OFF



STROBE

LIGHT

H/L0 RANGE
 FIRE PUMP
 FLASHERS

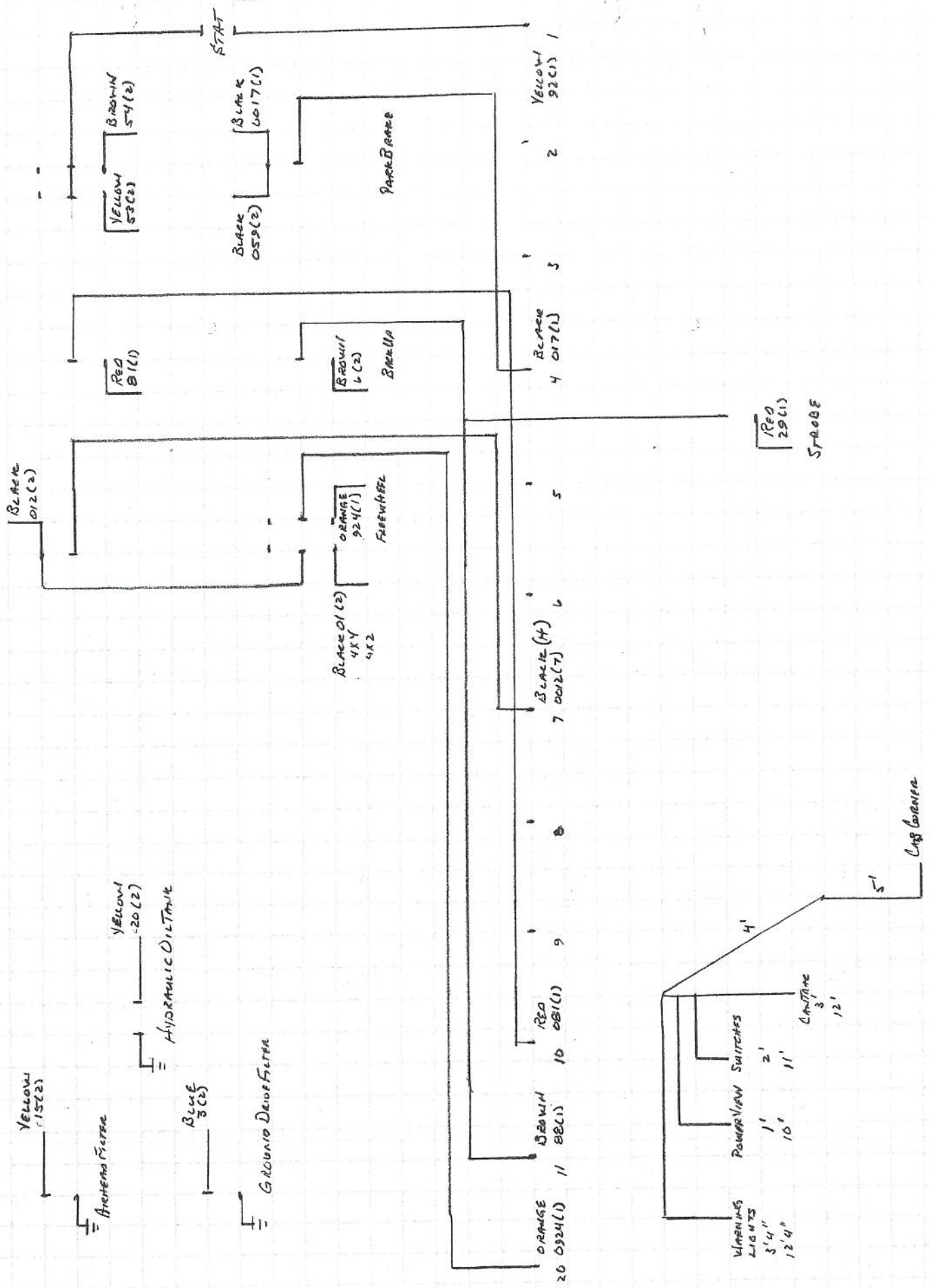

CENTERING

SECONDARY

STEERING

REVERSING

LEFT

RIGHT

LEFT
PRIMARY

RIGHT
PRIMARY

DISTRIBUTORS

BOOM

STAR REVERSING

REVERSING

LEFT

RIGHT

AIRHEAD
FEED

CROSS

FOOT PLATE SWITCHES

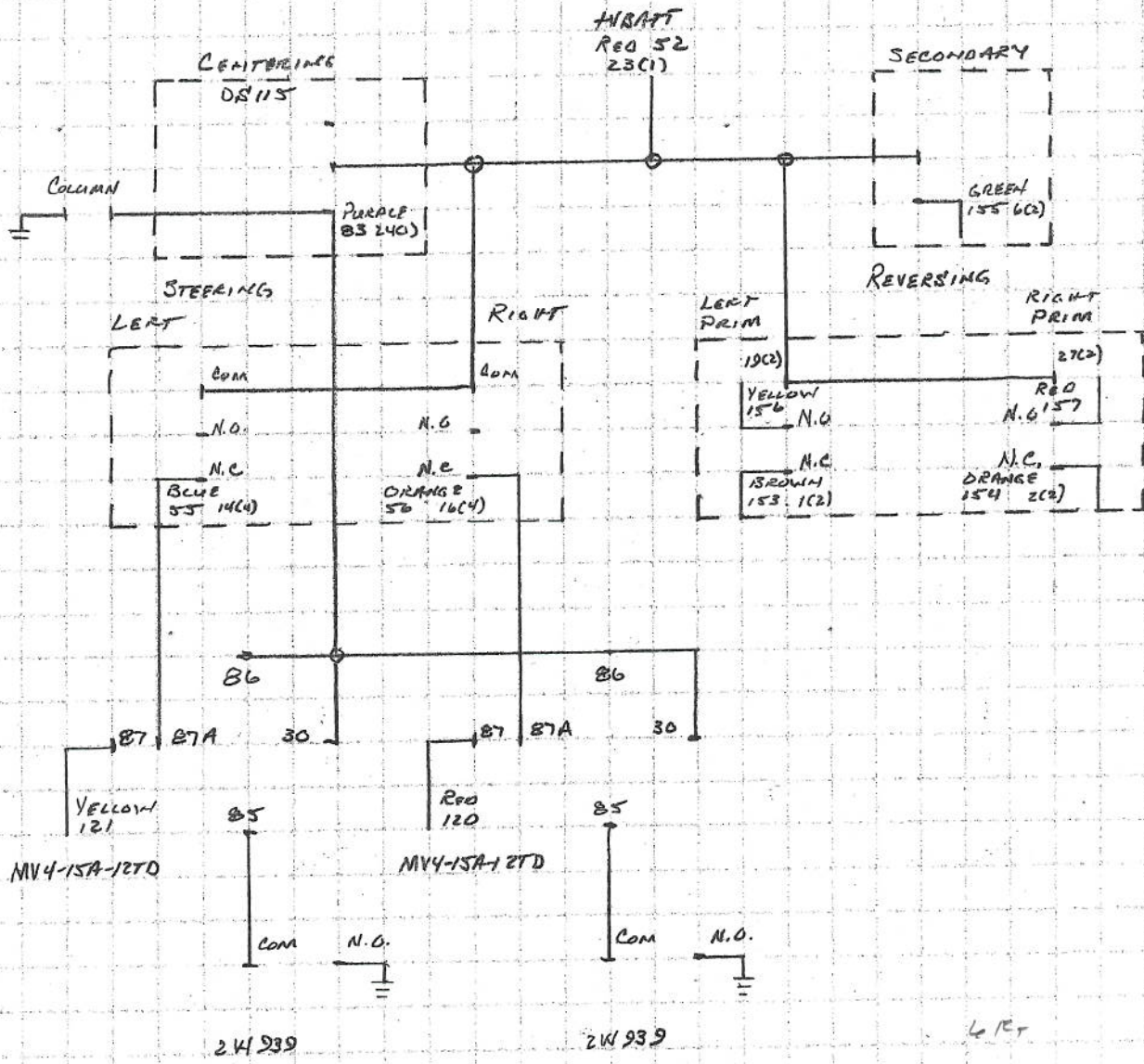
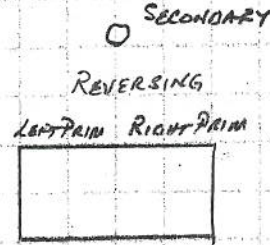
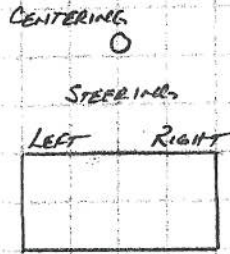

FOOT PLATE SWITCHES

DISTRIBUTORS ○
STAR REVERSING

LEFT RIGHT

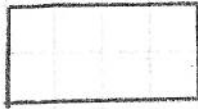

○ BOOM

REVERSING
AIR FEED CROSS

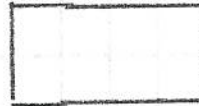

+12VDC

RED
052(B)

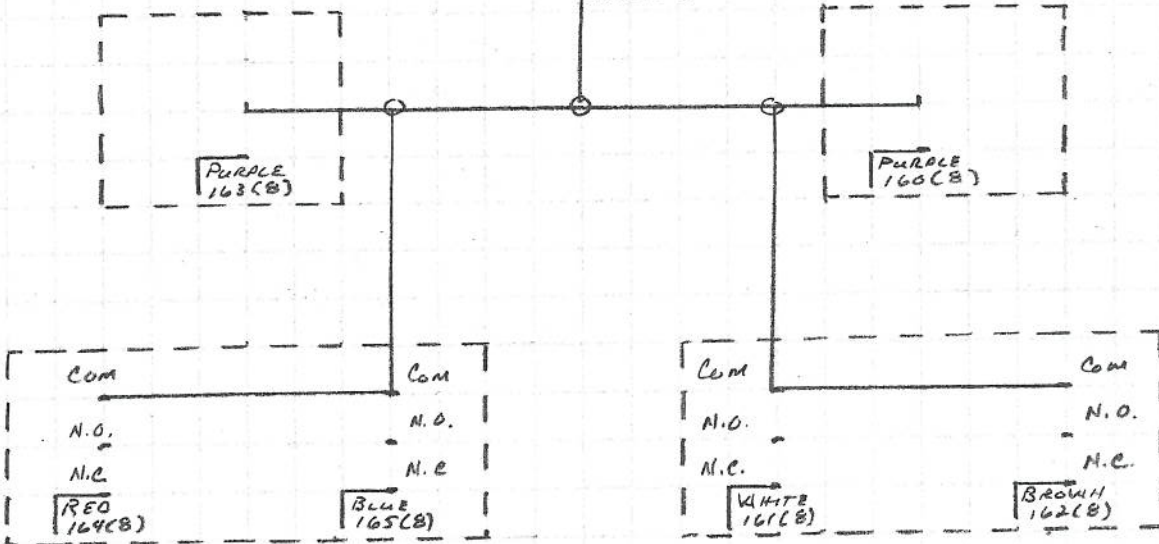

9 FT

AIR HEAD CLEANER

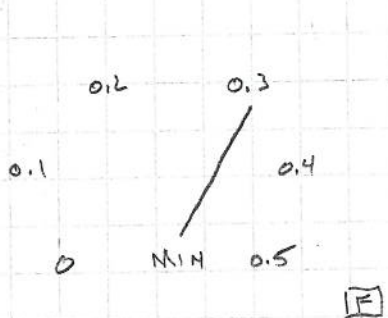
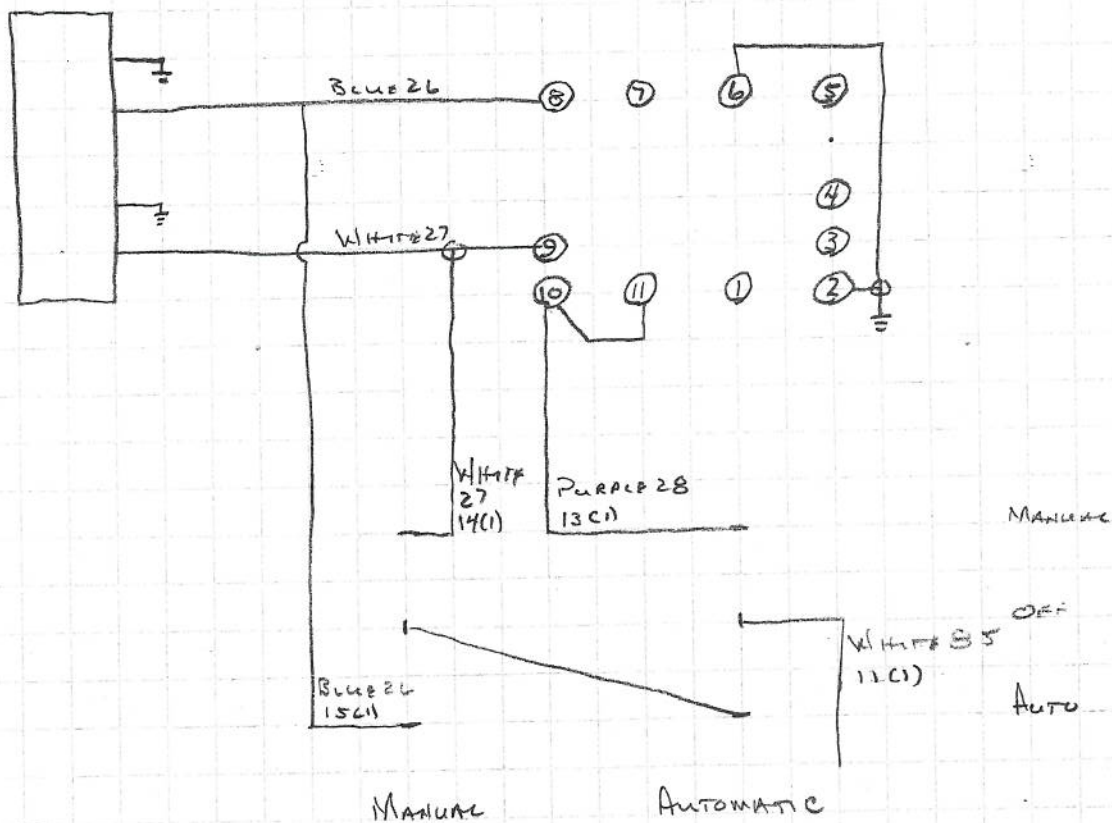

AT11DN-1
AUTONICS

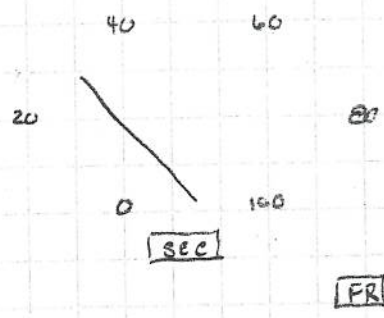

PM44A-H-DC12Y
PARASONIC

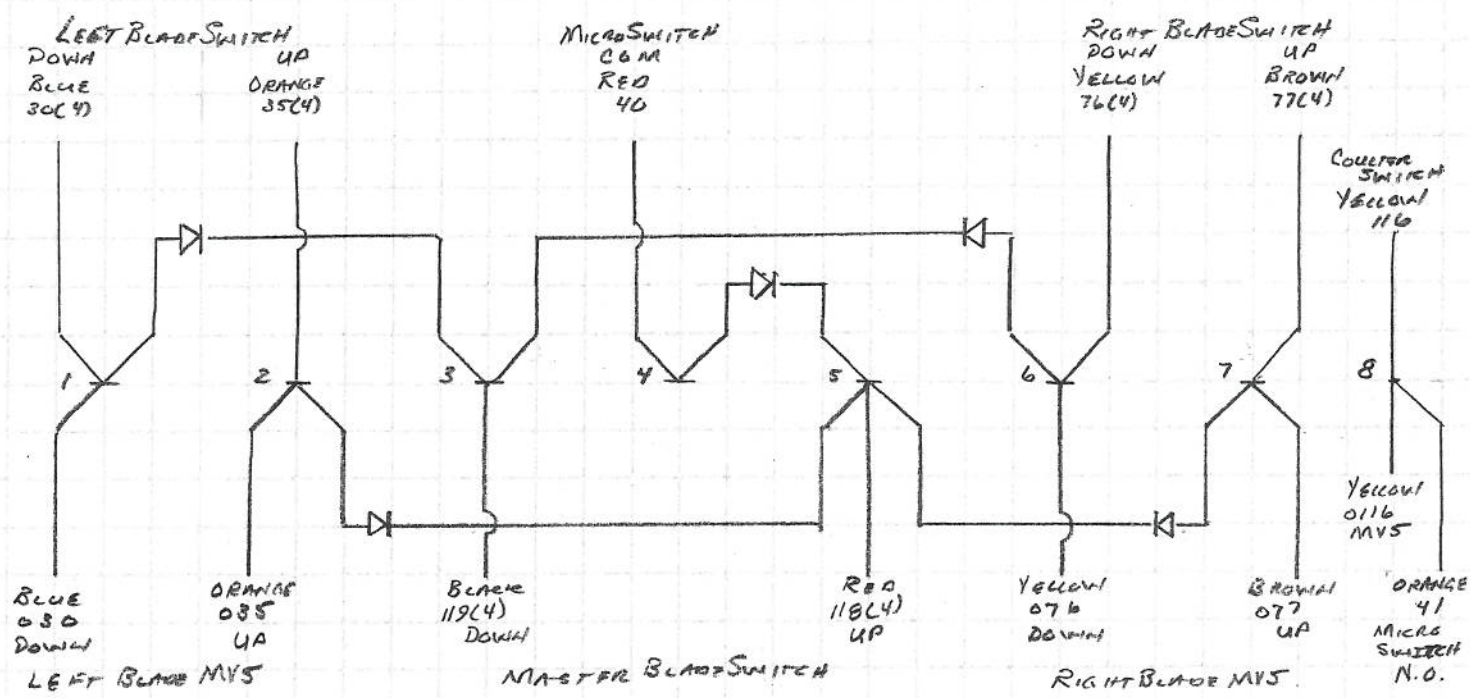

Pin 1	BLUE	30
2	ORANGE	35
3	RED	40
4	YELLOW	76
5	BROWN	77
6	YELLOW	116
7	BLUE	030
8	ORANGE	035
9	BLACK	119
10	RED	118
11	YELLOW	076
12	BROWN	077
13	YELLOW	0116
14	ORANGE	41
15		
16		

- 5 RECTIFIER 6A 264-6086 (276-1661)
- 1 ENCLOSURE (Q131310PCE) 78351/14069
- 4 1/2 MOUNTING TRACK 58371
- 8 TERMINAL BLOCKS 58364
- 2 END CLAMP 58373
- 1 END CAP 58363
- 14 S12-1220
- 14 S12-1225
- 1 S12-1160 16 PIN RECEPTACLE
- 1 S12-1114 16 PIN PLUG
- 1 S12-1280 RELIEF

14075

TUPLING FARMS

5/7/2014

4RSPH-65LAH

PLUG #1

PIN #				
1	Yellow	92	CB 1 To Hazard Stat Switch	
2	Green	91	CB 2 To Airhead Cleaner / Bin Fill Switches	
3	Orange	090	Reset Switch To Reset Relay	
4	Black	017	CB 4 To Brake, Steer, Warning , Speedometer Multiplier	
5	Red	081	CB 10 To Fuel Pump Switch	
6	Yellow	089	Reset Switch To Reset Relay	
7	Black	804	Seat Switch To Time Delay Relay Pin 6	
8	Black	810	Seat Switch To Time Delay Relay Pin 7	
9	Black	0017 ✓	Brake Switch To Brake Solenoid	Black 17
10	Brown	88	CB 11 To Backup Lights	
11	White	85	CB 12 To Actuator Switches	
12	Red	81 ✓	Fuel Pump Switch To Fuel Pump	
13	Purple	28	Airhead Cleaner Auto To Timer #10	
14	White	27 ✓	Airhead Cleaner Manual To Timer #9 To Solenoid	
15	Blue	26	Airhead Cleaner Manual To Timer #8 To solenoid	
16	Orange	924 ✓	4X4 Switch To Front Motor Freewheel Valve	
17	Orange	0924	CB 20 To 4X4 Switch Freewheel Side - 12vdc	
18	Red	29 ✓✓	Strobe Light	
19	Yellow	33 ✓	Shaker Switch To RDRS112-30 Actuator	
20	Red	32 ✓	Shaker Switch To RDRS112-30 Actuator	
21	Red	70 ✓	Airhead Feed RDRS112-30 Actuator	
22	Purple	69 ✓	Airhead Feed RDRS112-30 Actuator	
23	Red	52	CB 16 To Foot Switches - 12VDC	
24	Purple	83 ✓	Foot Switches To Steering Box	
25	Black	108 ✓	Stone Box MV5 Valve	
26	Red	109 ✓	Stone Box MV5 Valve	
27	Yellow	116 ✓	Coulter Switch To MV5 Valve	
28	Brown	117 ✓	Coulter Switch To MV5 Valve	
29	Black	95 ✓	Airhead Deflector Switch To MV5 Valve	
30	Brown	088	CB11 To Backup Switch In Cab	
31	Brown	0088 ✓	Backup Switch To Alarm	
32	Yellow	42 ✓	Bin Fill Speed Switch To RDRS112-30 Actuator	
33	White	43 ✓	Bin Fill Speed Switch To RDRS112-30 Actuator	
34	White	96 ✓	Airhead Deflector Switch To MV5 Valve	
35	White	65 ✓	Left Star RDRS112-30 Actuator	
36	Purple	66 ✓	Left Star RDRS112-30 Actuator	
37	Orange	50 ✓	Bin Unload Bypass SV3-16-0-123T-12DG Solenoid	

14075

TUPLING FARMS

2/6/2014

4RSPH-65LAH

PLUG 2

PIN #				
1	Brown	153 ✓	Left Primary Reverse	
2	Orange	154 ✓	Right Primary Reverse	
3	Black	059 ✓	Park Switch To 14(5) / 15(5) Red 0015 To Xm To SV4-10-0	
4	Yellow	752 ✓	Hydraulic Oil Temperature Sender - Gray-Pin A- To Cab	Yellow 752
5	Yellow	753 ✓	Hydraulic Oil Temperature Sender - Violet-Pin B- To Cab	Yellow 753
6	Green	155 ✓	Secondary Reverse	
7	Brown	54 ✓✓✓	Right Turn /Signal	
8	Yellow	53 ✓✓✓	Left Tun Signal	
9	Brown	6 ✓	Back-Up Lightg Switch To Relay	
10	Brown	505 ✓	Right Work Light Switch To Relay	Brown 505
11	Green	437 ✓	Primary Circuit Temperature Sender - Violet - Pin B- To Cab	Green 437
12	Black	1 ✓	4X4 Switch To Relay	
13	Black	12 ✓	2-Speed Switch To Solenoid / High Pressure Reliefs (2)	
14				
15	Brown	11 ✓	Bin Fill Switch To DTS-0373B (A) Solenoid	
16	Yellow	5 ✓	Airhead Feed Switch To DTS-0373B (A) Solenoid	
17	Brown	16 ✓	Cross Conveyor Switch To DTS-0373B (A) Solenoid	
18	Red	82 ✓	Star / Steel Rolls Switch To 3 DTS-0373B (B) Solenoid's	
19	Yellow	156 ✓	Left Primary Forward	
20	Yellow	15 ✓	Fan Return Filter #3 To Light	
21	Blue	3 ✓	Ground Drive Hi-Pressure Filter #3 To Light	
22	Yellow	20 ✓	Hydraulic level Sensor To Cab (BZL-13)	
23	White	61 ✓	Cross Pressure Switches To Cab BZ6562	
24	Black	22 ✓	Boom Switch To DTS-0373B (A) Solenoid	
25	Orange	143 ✓	CB 7 To Hydro Neutral Switch #1	
26	Orange	144 ✓	Hydro Handle Neutral Switch #2 To Relay	
27	Red	157 ✓	Right Primary Forward	
28	Green	607 ✓	DTS-0160 To Cab Speedometer	Green 607
29	Red	149 ✓	Steel Rolls Switch To RDRS112-30 Actuator	
30	Yellow	150 ✓	Steel Rolls Switch To RDRS112-30 Actuator	
31	Orange	145 ✓	Star Distributor Rolls Switch To RDRS112-30 Actuator	
32	Blue	146 ✓	Star Distributor Rolls Switch To RDRS112-30 Actuator	
33	Orange	147 ✓	Hump Shaft Actuator	
34	Blue	148 ✓	Hump Shaft Actuator	
35	Black	151 ✓✓	Star Table Spacing Actuator	
36	Green	425 ✓	Primary Circuit Temperature Sender - Gray-Pin A- To Cab	Green 425
37	Red	152 ✓✓	Star Table Spacing Actuator	

14075

TUPLING FARMS

5/7/2014

4RSPH-65LAH

PLUG 3

PIN				
*1	Red	18	CB 6 Wiper Power	P
2	Red	12	Radio Power From Plug 5 Pin 2	2 (5)
3	Purple	* 12	CB 6 To Purple "ACC" In Power View Harness	p
4	Black	20	Ground	P
5	Brown	503	Road Light Switch	P
6	Red	22	CB 8 To Dome - Panel Switches - Radio Memory	P
*7	Brown	507	Cab Field Lights Power	P
8	Brown	572	Work Light Switch To Left Work Light Relays	P
9	Purple	* 13	Purple "Key" In Power View Harness To Power Solenoids In Panel	P
*10	Brown	526	Cab Road Lights Power	P
11	Blue	652 /	Fuel Gauge	White 58 ✓
12	Red	* 11 ✓	Red "POW" In Power View Harness To Plug 5 Pin 1	1 (5)
13	Green	* 422	Green "STRT" In Power View Harness To Stater Relay	P
14	Brown	504	Field Light Switch	P
*15	Black	156	Auxillary Power Box	P
16				

PLUG 5

PIN #		COLUMN PLUG		
1	11	Red	To Red "POW" In Power View Harness	12 (3)
2	12	Red	Power From Key Switch "ACC" To Radio	2 (3)
3	13	Red	Key Switch "IGN" To Ignition Terminal On Power Solenoids In Panel	P
4	502	Brown	Power From Turn Stat	502 TO 507
5	104	White	Clutch Switch N.C. To Start Relay	P
14	059	Black	To Clutch Switch N.O. Position To 15 (5)	15 (5)
15	0015	Red	XM Switch Pin 1 / Pin 3 "N.O. Red 15 To Sv4 Solenoid	
18	522	Brown	Right Turn Signal - Brown 54 On Machine	512 To 522
20	523	Brown	Left Turn Signal - Yellow 53 On Machine	513 To 523

14075

TUPLING FARMS

5/7/2014

4RSPH-65LAH

PLUG 4

SW#/PIN#					
1	Red	21	CB 7 To Cab Overhead		
5	2	Brown	Boom Swing MV5 Valve	Purple	114
5	3	White / Brown	Boom Swing MV5 Valve	Green	115
6	4	Blue	Steptable Height MV5 Valve	Black	170
6	5	White / Blue	Steptable Height MV5 Valve	White	171
7	6	Violet			
7	7	White / Violet			
8	8	White / Gray	Left Blade Up Switch To Junction Panel	Blue	30
8	9	Gray	Left Blade Down Switch To Junction Panel	Orange	35
9	10	White / Green	Right Blade Up Switch To Junction Panel	Yellow	76
9	11	Green	Right Blade Down Switch To Junction Panel	Brown	77
10	12	White / Black / Orange	Blade Up Switch To Junction Panel	Red	118
10	13	White / Black / Yellow	Blade Down Switch To Junction Panel	Black	119
14	Blue	55	Left Crab Foot Switch To Steering Box Relay		
15	Green	605	Airhead Fan RPM Pickup To Cab		
16	Orange	56	Right Crab Foot Switch To Steering Box Relay		
17	Brown	37	Right Star Table RDRS112-30 Actuator		
18	Green	38	Right Star Table RDRS112-30 Actuator		
19	Blue	71	Bin Fill Manual Switch To MD3 (Down)		
20	Orange	72	Bin Fill Manual Switch To MD3 (Up)		
21	Red	75	Bin Fill Automatic Switch To MD3 Panel Junction Block		
22	White	41	Travel Mode Switch To MD3 / XA2 Modules		
23	White	371	Level Warning Light To MD3 / XA2 Modules		
24	Green	78	Bin Unload Switch to RDRS112-30 Actuator		
25	Brown	79	Bin Unload Switch To RDRS112-30 Actuator		
26	Yellow	76	Stone Switch To RDRS112-30 Actuator		
27	Green	77	Stone Switch To RDRS112-30 Actuator		
1	28	Black	Pinch Roll Height Switch To MV5 Valve	Green	166
1	29	White / Black	Pinch Roll Height Switch To MV5 Valve	White	167
2	30	Red	Pinch Roll Gap Switch To MV5 Valve	Blue	168
2	31	White / Red	Pinch Roll Gap Switch To MV5 Valve	Brown	169
3	32	Orange	Boom Outer Switch To MV5 Valve	Orange	110
3	33	White / Orange	Boom Outer Switch To MV5 Valve	Blue	111
4	34	Yellow	Boom Lift Switch To MV5 Valve	White	112
4	35	White / Yellow	Boom Lift Switch To MV5 Valve	Brown	113
36	White / Black / Green		Cyber Tech Handle To Panel Ground	Black	020
37	White		CB 2 To Cyber Tech Handle	Green	091

14075

TUPLING FARMS

5/7/2014

4RSPH-65LAH

PLUG 5

PIN #		COLUMN PLUG			
1	11	Red	To Red "POW" In Powerview Harness		12 (3)
2	12	Red	Power From Key Switch "ACC" To Radio		2 (3)
3	13	Red	Key Switch "IGN" To Ignition Terminals On 77007 Solenoids in Panel		P
4	502	Brown	Power From Turn Stat	502 To 507	P
5	104	White	Clutch Switch N.C. To Relay		P
14	059	Black	To Clutch Switch N.O. To 15 (5)		3 (2)
15	0015	Red	To XM Switch "COM" Pin #1 / N.O. Pin #3 On XM Red 15 To DTS-6505 Solenoid		
18	54	Brown	Right Turn Signal - Brown 54 On Machine	512 To 522	7 (2)
20	53	Brown	Left Turn Signal - Yellow 53 On Machine	513 To 523	8 (2)

PLUG #6

BELDEN 8619

1	Black	Airhead Controller Power Supply Junction 4	8619
2	Blue	Airhead Potentiometer Pin 2 Command Signal Junction 2	8619
3	Orange	Airhead Potentiometer Pin 3 Command Signal Junction 3	8619
4	White	Airhead Potentiometer Pin 1 Command Signal Junction 21	8619
5	Black / White	Left / Right Primary Controller Power Supply Junction 8	8619
6	Red	Left Primary Potentiometer Pin 1 Command Signal Junction 22	8619
7	Blue / White	Left Primary Potentiometer Pin 2 Command Signal Junction 6	8619
8	Green / White	Left Primary Potentiometer Pin 3 Command Signal Junction 7	8619
9	Red / White	Right Primary Potentiometer Pin 1 Command Signal Junction 23	8619
10	Blue / Black	Right Primary Potentiometer Pin 2 Command Signal Junction 10	8619
11	Red / Black	Right Primary Potentiometer Pin 3 Command Signal Junction 11	8619
12	Green / Black	Secondary Controller Power Supply Junction 16	8619
13	Orange / Black	Secondary Potentiometer Pin 1 Command Signal Junction 24	8619
14	Green	Secondary Potentiometer Pin 2 Command Signal Junction 14	8619
15	White / Black	Secondary Potentiometer Pin 3 Command Signal Junction 15	8619
16			

LARGE 3 PIN PLUG

PLUG #7

1	Orange	90 (H)	Main Power Reset Relay (N.O.) To Master Switch
2	Yellow	89 (H)	Main Power Reset Relay (N.O.) To Master Switch
3	Black	0012 (H)	CB 7 To Hi / Lo Switch

14075

TUPLING FARMS

5/7/2014

4RSPH-65LAH

PLUG #8

PIN

1	Red	028	Auxillary Power Outlet Pin #3 In Panel To Airhead Speed Switch
2	White	67 ✓	Cross Distributor Speed Switch To RDRS112-30 Actuator
3	Blue	68 ✓	Cross Distributor Speed Switch To RDRS112-30 Actuator
4	Purple	62 ✓	Cross Speed Switch To RDRS112-30 Actuator
5	Brown	63 ✓	Cross Speed Switch To RDRS112-30 Actuator
6	Black	51 ✓	Airhead Discharge Speed Switch To RDRS112-30 Actuator
7	Orange	52 ✓	Airhead Discharge Speed Switch To RDRS112-30 Actuator
8	Orange	47 ✓	Boom Speed Switch To RDRS12-30 Actuator
9	White	48 ✓	Boom Speed Switch To RDRS12-30 Actuator
10	Purple	73 ✓	Segment Roll Speed Switch To RDRS112-30 Actuator
11	Orange	74 ✓	Segment Roll Speed Switch To RDRS112-30 Actuator
12	Brown	80 ✓	Pinch Roll Speed Switch To RDRS112-30 Actuator
13	Yellow	84 ✓	Pinch Roll Speed Switch To RDRS112-30 Actuator
14	Green	93 ✓	Steptable Distributor Speed Switch To RDRS112-30 Actuator
15	Brown	94 ✓	Steptable Distributor Speed Switch To RDRS112-30 Actuator
16	Red	052	Auxillary Power Outlet Pin #6 To Left Foot Plate
17	Purple	160 ✓	Boom Reverse Foot Switch To Reversing Valve
18	White	161 ✓	Airhead Feed Foot Switch To Reversing Valve
19	Brown	162 ✓	Cross Foot Switch To Reversing Valve
20	Purple	163 ✓	Star Table Distributor Foot Switch To Reversing Valve
21	Red	164 ✓	Left Star Table Foot Switch To Reversing Valve
22	Blue	165 ✓	Right Star Table Foot Switch To Reversing Valve

23

24

BIN / AIR HEAD / CROSS / SIDE ELECTRONIC LEVELING

5/6/2014

MD3 MODULE (GRAY PLUG)

C1:1	- BATT	Ground - XA2 C1:15		(C1:15)
C1:2	CAN A-L	XA2 - C1:40		(C1:2)
C1:7	+RTC	12 Vdc Continuous From 10 Amp Fuse In Panel	Red 280	(C1:7)
C1:11	CAN A-H	XA2- C1:26		(C1:11)
C1:12	+ BATT	+12Vdc To XA2- C1:28		(C1:28)

MD3 MODULE (BLACK PLUG)

C2:4	DIN-D	Bin Auto Select	Red [(Red 75 (4)]	
C2:5	-VREF	MC2 COMM Cable	Black	
		Cross Pitch Sensor "-VREF"	Belden 9418	
			Black #6	
		Side Roll Sensor "-VREF"	Belden 9418	
			Black #7	
C2:6	USB-D-	MC2 COMM Cable	White	
C2:7	USB-D+	MC2 COMM Cable	Green	
C2:8	+VREF	Cross Pitch Sensor "+VREF"	Belden 9418	
			Red #6	
		Side Roll Sensor "+VREF"	Belden 9418	
			Red #7	
C2:9	DIN-E	Bin Manual Up	Orange 72 (4)	
C2:10	DIN-F	Bin Manual Down	Blue 71 (4)	
C2:11	DIN-G	Travel Mode Input	White 41 (4)	

VPL 324K2 INSTALLED 9/17/15
 To Speed Up Cycluson

**BIN / AIR HEAD / CROSS / SIDE ELECTRONIC LEVELING
XA2-XA MODULE**

5/6/2014

C1:1	ADDR-H	Termination Resistor	
C1:2	PWM-A	Airhead Pitch Control % To Both Valve Coils Pin "A"	Belden 9418 Black #2 White #2
C1:3	PWM-B	Airhead Roll Control % to Both Valve Coils Pin "A"	Belden 9418 Black #3 White #3
C1:4	PWM-C	Bin Level Control % To Both Valve Coils Pin "A"	Belden 9418 Black #1 White #1
C1:6	PWM-E	Side Conveyor Control % To Both Valve Coils Pin "A"	Belden 9418 Black #9 White #9
C1:7	PWM-F	Cross Level Control % To Both Valve Coils Pin "A"	Belden 9418 Black #8 White #8
C1:8	DOUT-A	System Error Lamp	White 371 (4)
C1:10	VIN-A	Bun Level Sensor Signal "In"	White
C1:12	VIN-C	Airhead Pitch Sensor Signal "In"	Belden 9418 White #4
C1:13	VIN-D	Airhead Roll Sensor Signal "In"	Belden 9418 White #5
C1:14	ADD-L	Termination Resistor	
C1:15	-BATT	Ground To MD3 C1:1	Black P
C1:16	PWM-A RET+	Airhead Pitch Control To One Valve Coil Pin "B"	Belden 9418 Red #2
C1:17	PWM-B RET+	Airhead Roll Control To One Valve Coil Pin "B"	Belden 9418 Red #3
C1:18	PWM-C RET+	Bin Level Control To One Valve Coil Pin "B"	Belden 9418 Red #1
C1:20	PWM-E RET+	Side Conveyor Control To One Valve Coil "B"	Belden 9418 Red #9
C1:21	PWM-F RET +	Cros Level Control % To One Coil Pin "B"	Belden 9418 Red #8
C1:24	FIN-A	Airhead Speed Sensor	Grreen 605
C1:25	VIN-F	Side Conveyor Roll Signal "In"	Belden 9418 White #7
C1:26	CAN-H	To MD3 (Black Plug) C1:11	Red 28 (P)
C1:28	+BATT	+12Vdc To MD3 (Gray Plug)	Belden 9418
C1:29	-VREF	Airhead Pitch Sensor "-VREF"	Black #4 Belden 9418 Black #5
		Airhead Roll Sensor "-VREF"	Belden 9418 Black #5
C1:30	PWM-A RET-	Airhead Pitch Control % To One Valve Coil Pin "B"	Belden 9418 Green #2
C1:31	PWM-B RET-	Airhead Roll Control % To One Valve Coil Pin "B"	Belden 9418 Green #3
C1:32	PWM-C RET-	Bin Level Control % To One Valve Coil Pin "B"	Belden 9418 Green #1
C1:34	PWM-E RET-	Side Conveyor Control % To One Valve Coil Pin "B"	Belden 9418 Green #9
C1:35	PWM-F-RET-	Cross Level Control % To One Valve Coil Pin "B"	Belden 9418 Green #8
C1:38	VIN-G	Cross Pitch Sensor Signal "In"	Belden 9418 White #6
C1:40	CAN-L	To MD3 (Clear) C1:2	
C1:42	+VREF	Airhead Pitch Sensor "+VREF"	Belden 9418 Red #4 Belden 9418 Red #5
		Airhead Roll Sensor "+VREF"	Belden 9418 Red #5

BIN / AIR HEAD / CROSS / SIDE ELECTRONIC LEVELING

5/6/2014

BIN SENSOR

CROSS PITCH SENSOR #6

Blue	Ground	Junc. 1	Black	Ground	Junc. 7
White	Signal	Junc. 20	White	Signal	Junc. 39
Brown	12Vdc	Junc. 6	Red	12Vdc	Junc. 10

AIRHEAD PITCH SENSOR #4

SIDE ROLL SENSOR #7

Black	- VREF	Junc. 33	Black	Ground	Junc. 7
White	Signal	Junc. 22	White	Signal	Junc. 30
Red	+ VREF	Junc. 41	Red	12Vdc	Junc. 10

AIRHEAD ROLL SENSOR #5

Black	- VREF	Junc. 33
White	Signal	Junc. 23
Red	+ VREF	Junc. 41

**AIR HEAD ENCLOSURE
BELDEN 8770 - #5**

PIN PLUC	ROLL	
PIN 1	White	Signal
2	Black	- VREF
3	Red	+ VREF

PITCH

BELDEN 8770 - #4

4	White	Signal
5	Black	- VREF
6	Red	+ VREF

BIN VALVE

BELDEN 9418 #1

PIN

White	A
Green	B
Black	A
Red	B

A.H. PITCH VALVE BELDEN 9418 #2

White	A
Green	B
Black	A
Red	B

A.H. ROLL VALVE BELDEN 9418 #3

White	A
Green	B
Black	A
Red	B

CROSS VALVE BELDEN 9418 #8

White	A
Green	B
Black	A
Red	B

SIDE VALVE BELDEN 9418 #9

White	A
Green	B
Black	A
Red	B