

Project : OHIO Power Systems

6 Appendix A – Circuit Block Diagram for CANtrak & GPSI to OHIO Power System's Sensors

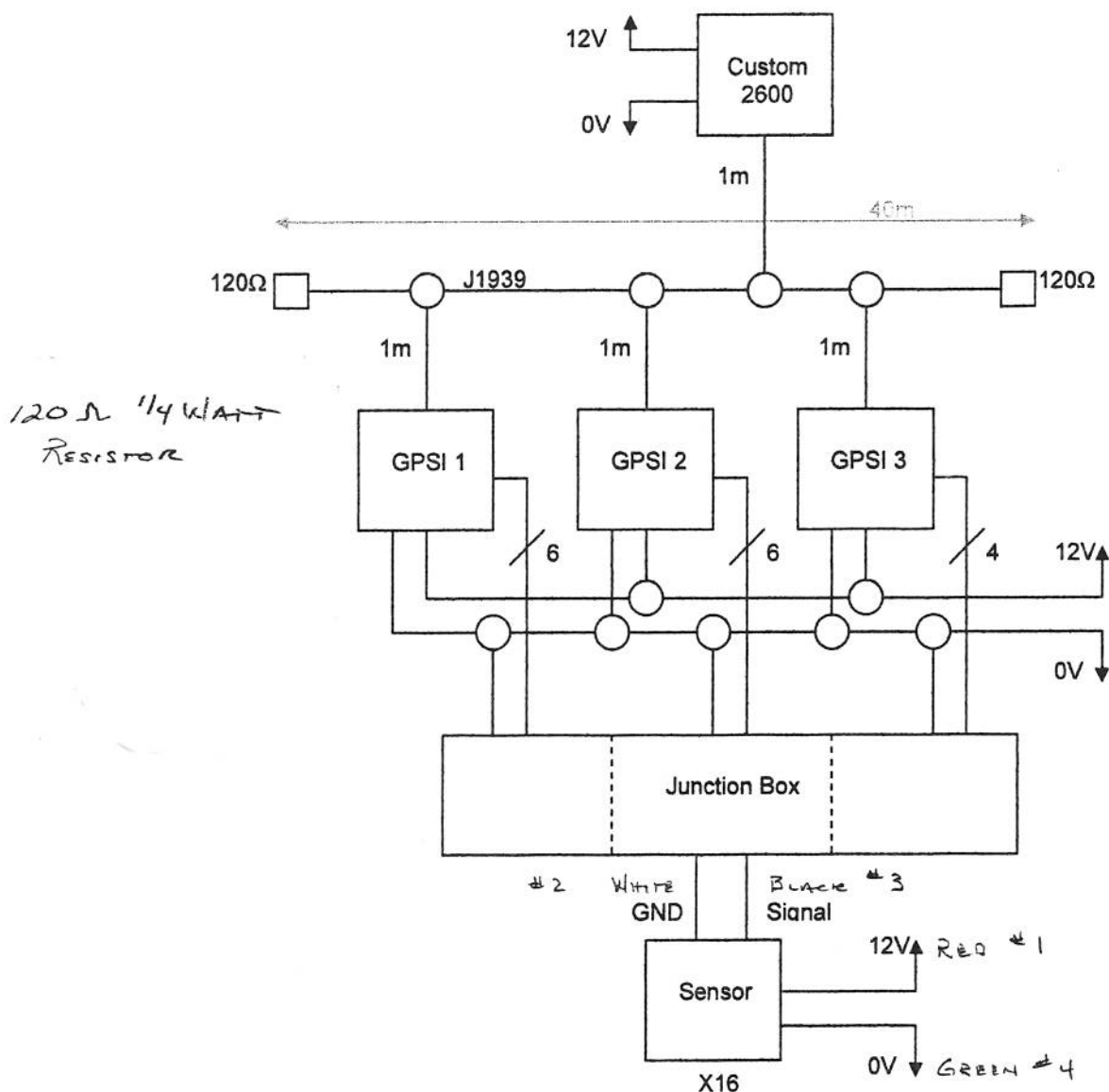

The CAN bus should be a shielded twisted pair, with impedance 120Ω. The shield ground should be connected to 0V.

'CAN+' (App.B GPSI Connector B pin 6) and 'CAN HI' (App.C CANtrak pin 8) should be linked.
 'CAN -' (App.B GPSI Connector B pin 7) and 'CAN LO' (App.C CANtrak pin 7) should be linked.
 GPSI Ground (App.B Connector B pin 1) and CANtrak Ground (App.C CANtrak pin 1) should be common.

GPSI Power (App B Connector B pin 12) should be tied to +12V.

OUT+ of each sensor should be connected to the relevant Analog input on GPSI (see 4.1)
 Each sensor's Ground and Earth should be common and IN+ tied to 12V.

Project : OHIO Power Systems

6 Appendix A – Circuit Block Diagram for CANtrak & GPSI to OHIO Power System's Sensors

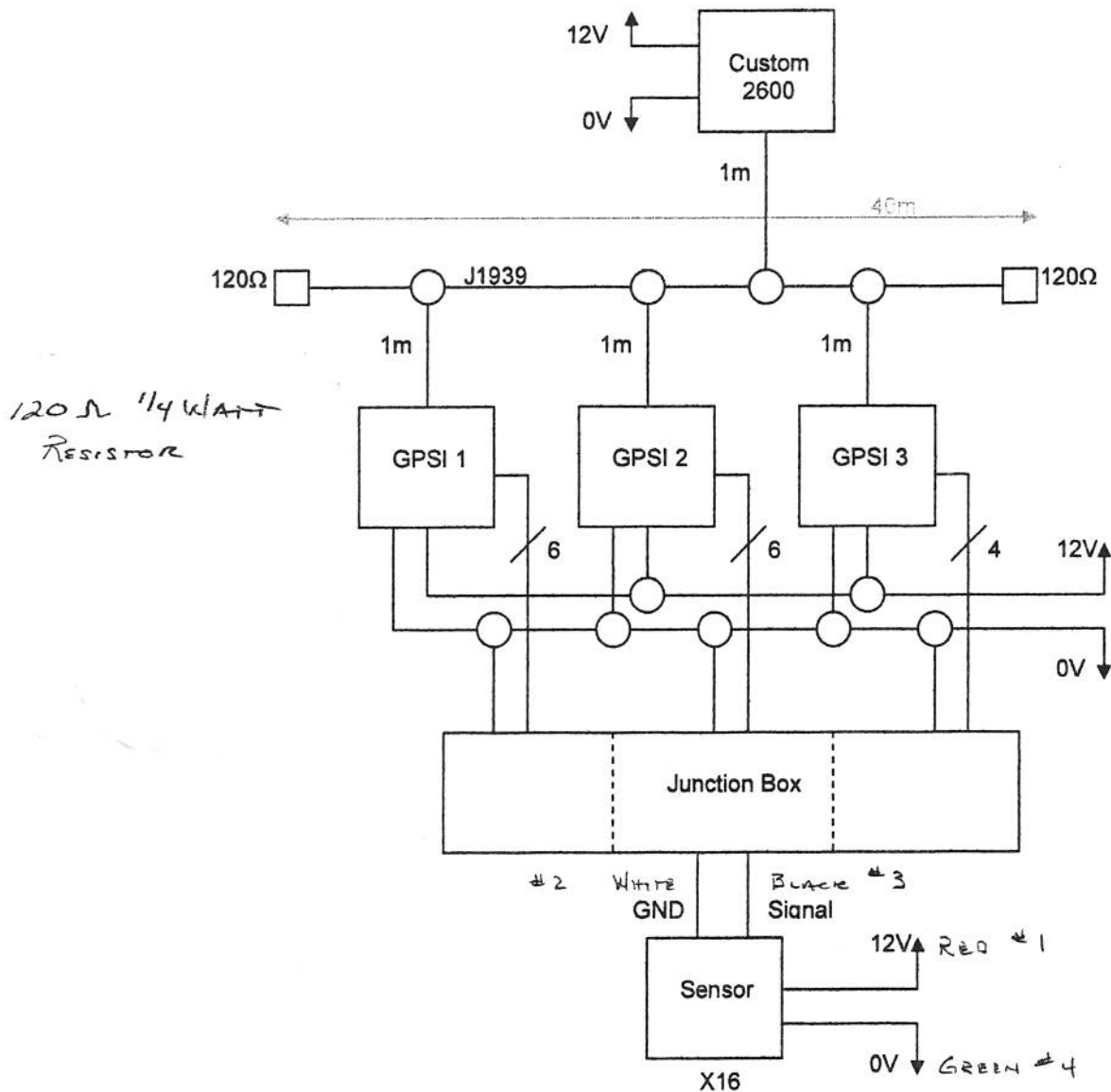

The CAN bus should be a shielded twisted pair, with impedance 120Ω. The shield ground should be connected to 0V.

'CAN+' (App.B GPSI Connector B pin 6) and 'CAN HI' (App.C CANtrak pin 8) should be linked.
 'CAN -' (App.B GPSI Connector B pin 7) and 'CAN LO' (App.C CANtrak pin 7) should be linked.
 GPSI Ground (App.B Connector B pin 1) and CANtrak Ground (App.C CANtrak pin 1) should be common.

GPSI Power (App B Connector B pin 12) should be tied to +12V.

OUT+ of each sensor should be connected to the relevant Analog input on GPSI (see 4.1)
 Each sensor's Ground and Earth should be common and IN+ tied to 12V.